



Flexo.RFID
Operating Manual



reddot winner 2023



GERMAN
DESIGN
AWARD
WINNER
2024

Flexo.RFID

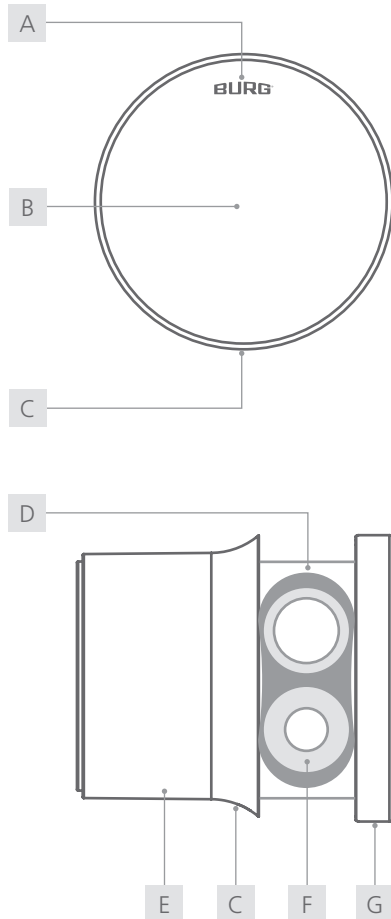

- | | |
|--------------------------|------------------------------|
| A LED | B RFID antenna |
| C closure hole | D battery compartment |
| E housing | F battery |
| G operating panel | |

Content

General.....	2
Technical data.....	3
Default settings.....	3
Scope of delivery.....	3
Optional accessories.....	3
Features.....	3
Mounting dimensions.....	3

Product dimensions.....	4
Functional description.....	4
LED- & sound signals.....	4
Guarantee of transponder compatibility.....	5
Commissioning.....	5
Configuration.....	5 - 6
Operation.....	6
Assembly flush-fit.....	7
Assembly retro-fit.....	8
Battery change.....	9
Conformity / Certification.....	10
Guarantee and warranty.....	10
Cleaning and care instructions.....	10
Disposal and battery note.....	10
Contact.....	10

General

The latest version of this guide is available at:
www.burg.de

Important notes:

- Please observe all important notes and read the entire operating manual before starting the configuration.
- Before putting the locking system into operation, refer to "Commissioning" on page 5.
- Master cards must be kept in a safe place. If lost, no further configurations can be made.

To the video:
operation



To the video:
assembly (flush fit)



Factsheet

Front view



Back view



Technical Data	
Dimension	Ø 50 mm
Battery	VARTA ¹ ½ AAH-R (2x) 850 mAh, CR High Power
Locking cycles ¹	approx. 25,000
Material	housing: plastic stator: zamak
Humidity (rel.)	10% - 80%
Temperature range	working temperature: 0°C to 55°C storage temperature: -20°C to 70°C
Degree of soiling	2
IP class	IP30
Application area	indoor
Mounting dimension	retro-fit: 16 mm x 19 mm flush-fit: 44,55 mm x 46,5 mm
Max. door thickness	22 mm
Lock attachment	retro-fit: M19 nut (1x) flush-fit: Flexo.Nut (1x)
Cam type	B
Locking direction	left (90°), door hinge: DIN right right (90°), door hinge: DIN left
Mode	multi-user mode (default), private mode
RFID types	MIFARE® Classic 1K (read / write), MIFARE® DESFire® EV (read)
No. of master cards	max. 3
No. of manager cards	max. 2
No. of user cards	max. 10

Default Settings

Mode	multi-user mode
Occupancy identification	on

Scope of Delivery

- 1x locking system
- 1x cam fixing screw² (M6 x 12 mm)
- 1x M19 nut (assembly: retro-fit)
- 1x Flexo.Ring (mounted) / Flexo.Nut (assembly: flush-fit)

Optional Accessories

- battery (VARTA¹ ½ AAH-R)
- anti-twist protection (W-MSZ-01)
- master card
- function card „mode switch“
- function card „reset“
- sector card set (sector 0 to sector 15)
- opening pin
- cam type B (order-related)

Features

- ergonomic handling and high-quality design
- external battery access and battery change
- RFID types: MIFARE® Classic 1K / MIFARE® DESFire® EV
- integrated occupancy identification with MIFARE® Classic 1K
- easy to retrofit, e.g. to replace mechanical locks
- adjustable cam (in 90° steps)

Mounting Dimensions³

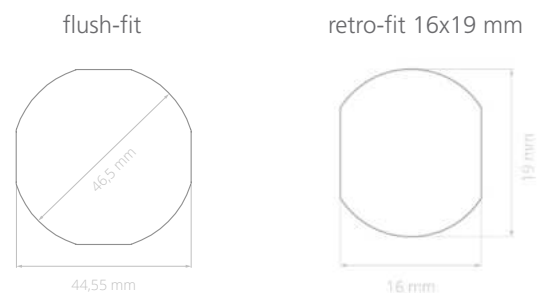

¹ The lock is approved for VARTA brand batteries. The use of other batteries may result in a reduced number of possible locking cycles.

² The use of a screw with a different length may cause damage to the lock.

³ Mounting dimensions and templates (STEP files) for milling, punching or lasering can be requested from BURG.

Product Dimensions

Front view

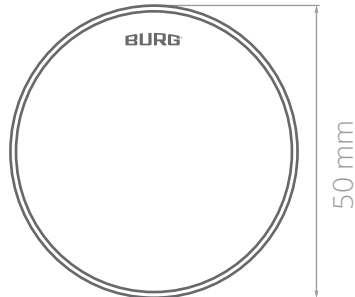

Side view

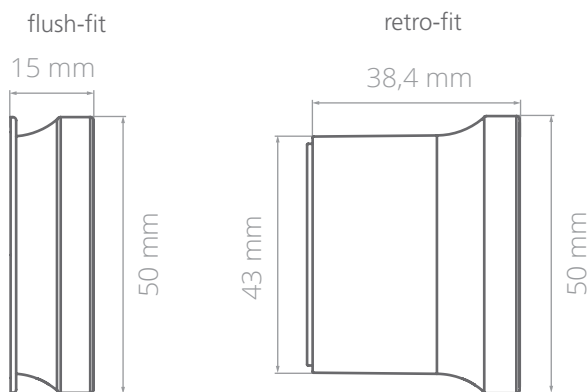

Functional Description

For operation with MIFARE® DESFire® EV transponders, the occupancy identification must be deactivated (chapter: Configuration, point **4c** "Deactivate occupancy identification")

Mode: multi-user authorization (multi-user mode)

This mode is suitable for changing user groups where the locker is only used temporarily or once, e.g. in a sports facility. Transponder media are valid for a single locking process and are deleted from the lock when the compartment is reopened. The lock remains open until a new transponder medium locks the lock again.

Mode: fixed assigned authorization (private mode)

In this mode, a transponder medium is preset with which the lock can be operated. This mode is suitable for user groups where the usage rights should not change permanently, e.g. for an office cabinet. The lock can only be operated with a stored transponder medium. Transponder media that are not stored are rejected by the lock.

Master card

The master card can open the lock regardless of the set mode (emergency opening). In multi-user mode, the transponder medium used for locking is deleted from the lock. The master card also authorizes the programming of master, manager and user cards (in private mode).

Occupancy identification (for multi-user mode)

During the locking process, the transponder medium used for locking is assigned an occupancy identification. The occupancy identification prevents the transponder medium from locking another lock. The occupancy identification is canceled again during the opening process.

Note: This function is only possible with MIFARE® Classic 1K transponder media. The occupancy identification can also be deleted from the transponder medium using the release box (e.g. after opening with a master card or manager card).

Manager card

The manager card can unlock the lock regardless of the set mode (emergency opening).

Mode card

The mode card can be used to change the mode (multi-user mode / private mode).

Reset card

The reset card deletes all cards and transponder media (master cards, manager cards and user cards).

Note: The reset card can only be used when the lock is unlocked.

LED locking indication

If the lock is locked, the red LED flashes at short intervals.

Automatic locking (for private mode)

After unlocking, the lock locks automatically after a few seconds. The latch function allows the door to be closed by pressing slightly.

Battery warning

If the battery voltage falls below a certain level (*phase 1*), three descending beeps sound when a transponder medium is presented. The lock can still be operated. If the voltage drops further (*phase 2*), the lock can no longer be locked. If the voltage falls into the critical range (*phase 3*), the lock can no longer be operated.

LED & Sound Signals

Green LED (flashes briefly) / signal tone (ascending)

Acceptance of authorized transponder media and successful unlocking process / configuration step.

Green LED (flashing)

The lock is in configuration mode.

Red LED (flashes briefly)

Successful locking process or successful mode change to private mode.

Red LED (flashing)

The lock is locked.

Red LED (3x flashing) / signal tone (3x short)

Canceling the configuration process.

Red LED (8x flashing) / signal tone (4x short)

Rejecting unauthorized transponder media.

Guarantee of transponder compatibility

When using RFID transponder media that have not been approved by BURG, no guarantee of compatibility is given.

Commissioning

- The first card that is held in front of the lock during commissioning or after deleting the cards / resetting is stored as the **master card**.
- We recommend to assign all 3 master cards during commissioning and keeping the master cards in a safe place.

1 First steps

1. Remove the lock from packaging and open the battery compartment (for help, see page 9 "Battery change").
2. Insert the batteries according to the (+ / -) symbols. Wait for the beep, the green and then the red LED. Close the battery compartment.
3. Hold the **master card** to be assigned centrally in front of the knob. A beep and the green LED confirm the successful process.

Note: To assign further master cards, follow point 1a - "Further master cards" in the chapter "Configuration".

Configuration

Unauthorized cards are rejected by the lock with four short beeps and the red LED flashing 8 times.

1 Assign cards

a) Further master cards

1. Hold the master card **2x** centrally in front of the knob. The first time the card is held in front of the lock, an ascending beep sounds and the green LED lights up. The lock is now unlocked. When the card is held in front of the knob again, a short beep sounds and the green LED starts to flash.
2. Hold the master card to be assigned centrally in front of the knob. A beep confirms the successful process.
3. If required, hold further master cards in front of the knob while flashing.
4. Wait until the LED stops flashing.

Note: Max. 3 master cards can be assigned.

b) Manager cards

1. Hold the master card **4x** centrally in front of the knob. The first time the card is held in front of the lock, an ascending beep sounds and the green LED lights up. The lock is now unlocked. When the card is held in front of the knob again, a short beep sounds and the green LED starts to flash.
2. Hold the manager card to be assigned centrally in front of the knob. A beep confirms the successful process.
3. If required, hold further manager cards in front of the knob while flashing.
4. Wait until the LED stops flashing.

Note: Max. 2 manager cards can be assigned.

c) User cards (private mode)

1. Hold the master card **3x** centrally in front of the knob. The first time the card is held in front of the lock, an ascending beep sounds and the green LED lights up. The lock is now unlocked. When the card is held in front of the knob again, a short beep sounds and the green LED starts to flash.
2. Hold the user card to be assigned centrally in front of the knob. A beep confirms the successful process.
3. If required, hold further user cards in front of the knob while flashing.
4. Wait until the LED stops flashing.

Note: Max. 10 user cards can be assigned.

2 Delete cards

This process deletes all cards from the lock. Cards cannot be deleted individually. The set mode remains active.

a) Via reset card

1. Hold the master card **1x** centrally in front of the knob. An ascending beep sounds and the green LED lights up. The lock is now open.
2. Hold the reset card **1x** centrally in front of the knob.
3. Two beeps and the green LED flashing twice confirm the successful process.
4. Wait until the LED stops flashing.

b) Via master card

1. Hold the master card **6x** centrally in front of the knob. The first time the card is held in front of the lock, an ascending beep sounds and the green LED lights up. The lock is now unlocked. When the card is held in front of the knob again, a short beep sounds and the green LED starts to flash.
2. A beep and the green LED confirm the successful process.

3 Change mode (via mode card)

During this process, all manager cards and user cards are deleted from the lock.

1. Hold the master card **1x** centrally in front of the knob. An ascending beep sounds and the green LED lights up. The lock is now open.
2. Hold the reset card **1x** centrally in front of the knob.
3. A beep and the red LED flashing once (private mode) or three beeps and the green LED flashing three times (multi-user mode) confirm the successful process.

4 Set the occupancy identification

a) Delete occupancy identification from user cards

The **Release Box** is required for this process. The user card can be used again after deletion.

1. Hold the user card centrally on the release box.
2. A beep and the green and then the blue LED¹ confirm the successful process.

b) Change sector for the occupancy identification

The **sector card set** is required for this process. By default, the occupancy identification is written to sector **15**.

1. Hold the required sector card (sector card **1** to **15**) centrally in front of the knob.
2. A beep sounds per sector. A long beep confirms the successful process.

c) Deactivate occupancy identification

The **sector card set** is required for this process.

1. Hold the sector card **0** centrally in front of the knob. A long beep confirms the successful process.

Operation

Unauthorized cards are rejected by the lock with four short-beeps and the red LED flashing 8 times.

1 Multi-user mode

a) Lock

1. Close the door. Turn the knob back to the starting position (logo on top).
2. Hold the user card centrally in front of the knob. Two ascending beeps and the red LED confirm the successful process.

b) Unlock

1. Hold the user card centrally in front of the knob. Two ascending beeps and the green LED confirm the successful process.
2. Turn the knob to the open position and pull the door open.

2 Private mode

a) Unlock

1. Hold the user card centrally in front of the knob. Two ascending beeps and the green LED confirm the successful process.
2. Turn the knob to the open position and pull the door open.

b) Lock

The lock locks automatically within a few seconds. The red LED flashes briefly. To close, press the door shut and turn the knob back to the starting position (logo on top) until it clicks into place.

3 Unlock via master card / manager card

During this process, the user card used for locking is deleted from the lock in multi-user mode. If the occupancy identification is activated, it can no longer be used until the occupancy identification is canceled. In private mode, the assigned user cards are retained.

1. Hold the master card or manager card centrally in front of the knob. An ascending beep and the green LED confirm the successful process.
2. Turn the knob to the open position and pull the door open.

¹ LED signal may differ for older release boxes.
Flexo.RFID | 04-24

Assembly Flush-Fit

Mounting dimensions and templates (STEP files) for milling, punching or lasering can be requested from BURG.

- 1 Prepare the mounting hole according to the mounting dimensions on the front of the door.



- 2 Insert the lock into the mounting hole from the front (outside of the door) and hold it in this position. Make sure that the BURG logo is at the top of the lock. Fit the Flexo.Nut from the rear and tighten it hand-tight.



- 3 Fit the cam and secure it with the enclosed Torx screw (Torx 30).

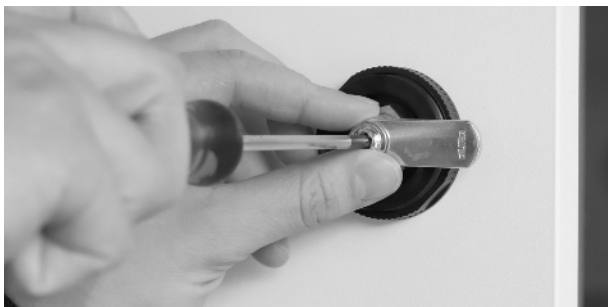

- 4 Then check whether the cam has sufficient hold on the striking plate or the rebate when closed. It should be possible to turn the cam to its end position without pressure or resistance when locking the locking system.

Note: The locking can be optimally adjusted using an adjustable striking plate. For more information, please get in touch with your contact at BURG.



Assembly Retro-Fit

Mounting dimensions and templates (STEP files) for milling, punching or lasering can be requested from BURG.

- 1 Prepare the mounting hole according to the mounting dimensions on the door front. Please note that an adapted two-stage recess may need to be milled for fronts made of wood and MDF. This recess is not required for metal fronts.

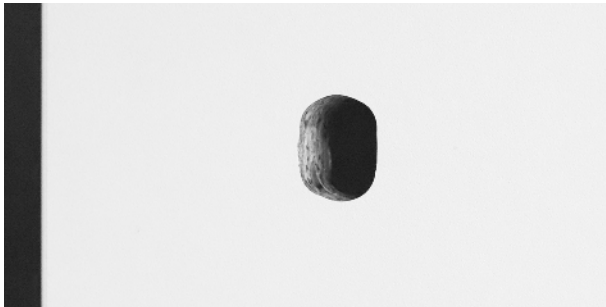

- 2 Insert the lock into the mounting hole from the front (outside of the door) and hold it in this position. Make sure that the BURG logo is at the top of the lock.



- 3 Fit the nut (M19) from the rear and tighten it hand-tight using a socket wrench (SW22).



- 4 Fit the cam and secure it with the enclosed Torx screw (Torx 30).



- 5 Then check whether the cam has sufficient hold on the striking plate or the rebate when closed. It should be possible to turn the cam to its end position without pressure or resistance when locking the locking system.

Note: The locking can be optimally adjusted using an adjustable striking plate. For more information, please get in touch with your contact at BURG.



Battery Change

The **opening pin** is required to change the battery. To open the battery compartment, only the housing (shown as a gray area in the sketches) needs to be turned.

- 1 When disassembled, the lock must be held in place on the stator (retro-fit) or on the Flexo.Ring (flush-fit). When fitted, the lock does not need to be held in place.

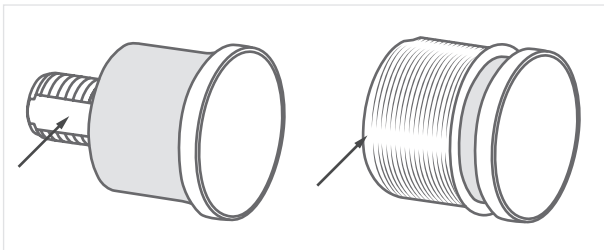

- 2 Carefully insert the opening pin into the closure hole underneath the operating panel until resistance is reached and press lightly.

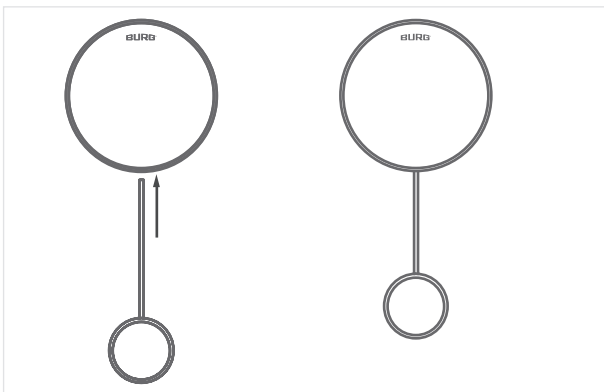

- 3 Hold the opening pin in position and turn the pin with the housing (shown as a gray area in the sketch) counterclockwise by approx. 10°. The operating panel is not rotated during this process.

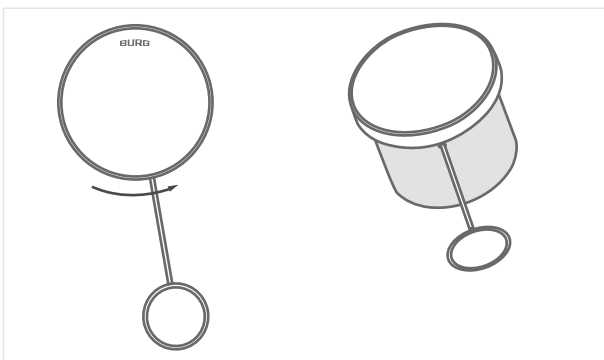

- 4 Remove the opening pin and pull the operating panel forwards.

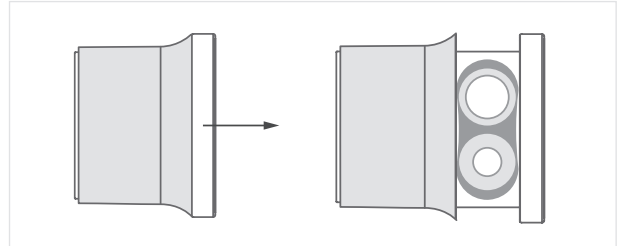

- 5 Remove the battery compartment cover. Replace the batteries according to the (+/-) symbols and reinsert the battery compartment cover.

- 6 Push back the operating panel. Carefully turn the housing (shown as a gray area in the sketches) clockwise until it clicks into place.

Conformity / Certification

CE Declaration of Conformity

Hereby, **BURG Lüling GmbH & Co. KG** declares that the radio equipment, type **Flexo.RFID**, is in conformity with Directives 2014/53/EU and 2011/65/EU. The full text of the EU Declaration of Conformity can be found at the following link:

https://www.burg.de/files/downloads/Declaration-of-Conformity/BURG_DoC_FlexoRFID_EN.pdf



Guarantee and Warranty

The warranty is subject to the statutory provisions. If you have any questions, please contact a specialist dealer or use the contact details below. Spare parts can be found at specialist dealers or at: www.burg.shop

Cleaning and Care Instructions

Remove the batteries before cleaning the appliance. Carefully clean the surfaces of the appliance with a damp, clean cloth. Chemical cleaning agents must not be used. Do not allow dust or liquids to enter the device.

Disposal and Battery Note

EU Directive 2012/19/EU regulates the proper take-back, treatment and recycling of used electronic devices.

Every consumer is legally obliged to dispose of batteries, rechargeable batteries or electrical and electronic devices ("old devices") that are powered by batteries or rechargeable batteries separately from household waste, as they contain harmful substances and valuable resources. They can be disposed of at an approved collection or take-back point, e.g. a local recycling center. Old appliances, batteries and rechargeable batteries are accepted there free of charge and recycled in an environmentally friendly and resource-saving manner. Old electrical appliances, used batteries or rechargeable batteries can also be returned to us. The return shipment must be sent with sufficient postage to the address below. The following symbol on waste electrical equipment, batteries or rechargeable batteries indicates that they must not be disposed of with household waste:



Important notes on the use of batteries:

- The use of high-quality brand batteries is essential for the correct functioning of the locking system. BURG locking systems are approved ex works for the specified industrial batteries of the VARTA brand. The use of batteries of other brands can lead to a reduced number of possible locking cycles as well as to limited functionality and functional problems, as experience has shown that batteries of other brands even with the same specifications have different performance characteristics. BURG does **not guarantee** the functionality of the locking system when using batteries of a brand other than those specified above.
- If both batteries are removed at the same time when changing the batteries or over a longer period of time, settings relating to the integrated real-time clock (RTC) will be lost.
- The battery may explode or release flammable gases if it is handled incorrectly, destroyed or the wrong type of battery is used. Do not recharge the battery, disassemble it, expose it to extremely high temperatures or throw it into a fire. Batteries containing harmful substances are labeled with abbreviations for the substances cadmium (*Cd*), mercury (*Hg*) and lead (*Pb*). If the lock is not used for a longer period of time, the batteries must be removed.

Contact

BURG Lüling GmbH & Co. KG

Volmarsteiner Str. 52
58089 Hagen (Germany)
+49(0)23 35 63 08-0

info@burg.de
www.burg.de